

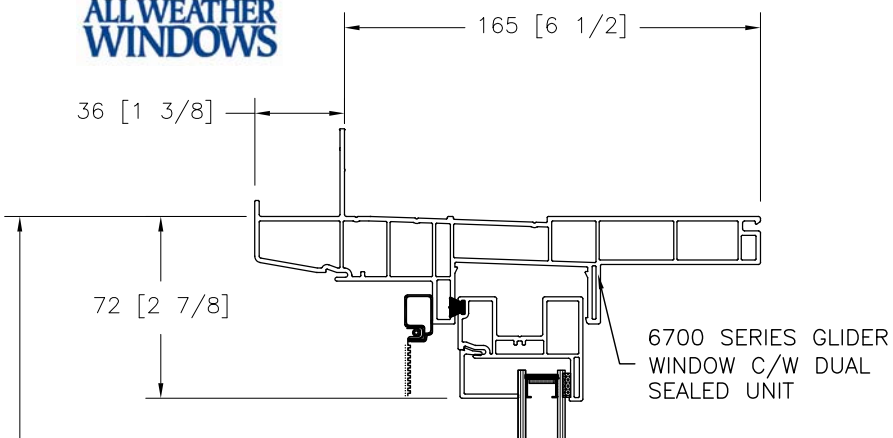

ALPINE

ULTIMATE PVC GLIDER WINDOWS

6700 SERIES
SECTION DETAILS
GLIDER



HEAD DETAIL
FRAME DIMENSIONS

SECTION A - A

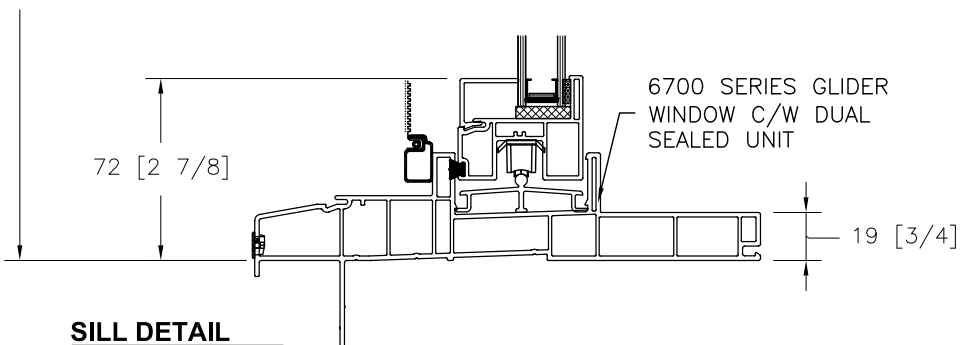
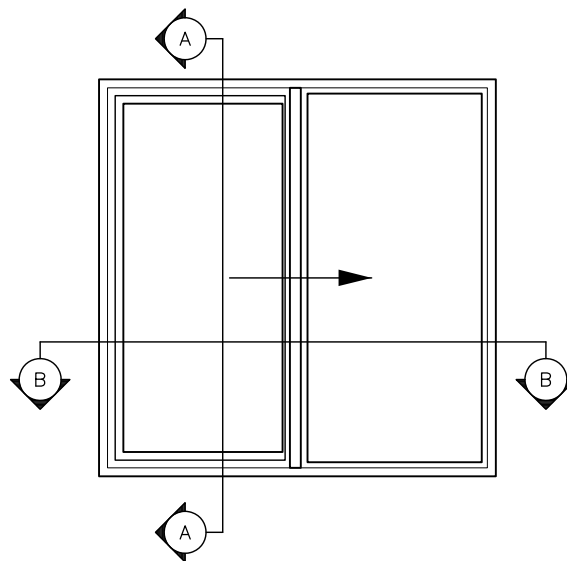

SILL DETAIL
FRAME DIMENSIONS

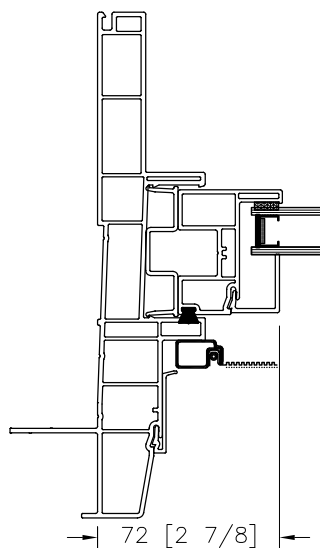

JAMB DETAIL
FRAME DIMENSIONS

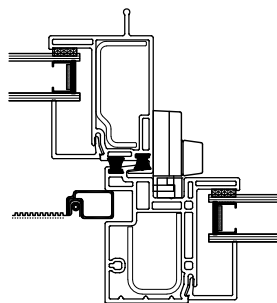

SECTION B - B

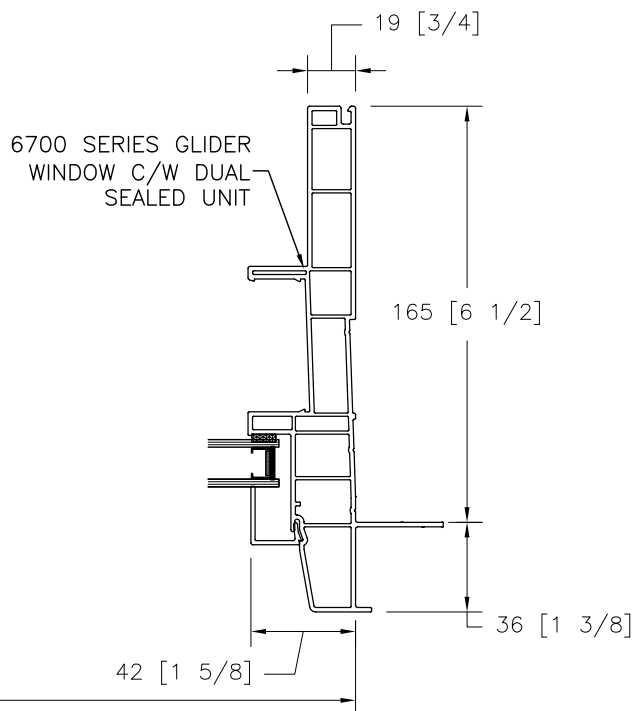

OSM FRAME WIDTH



ALPINE

ULTIMATE PVC GLIDER WINDOWS

6700 SERIES
SECTION DETAILS
MULLIONS

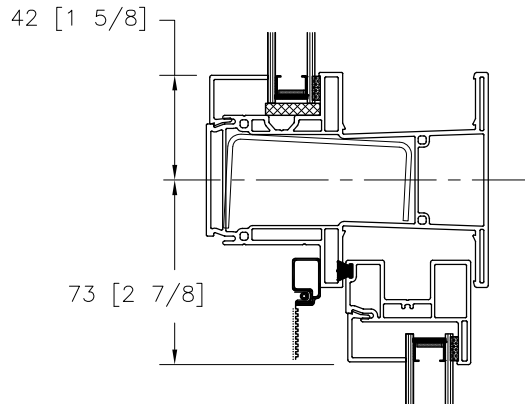

A. PICTURE / GLIDER
MULLION DETAIL C/W STEEL REINFORCING

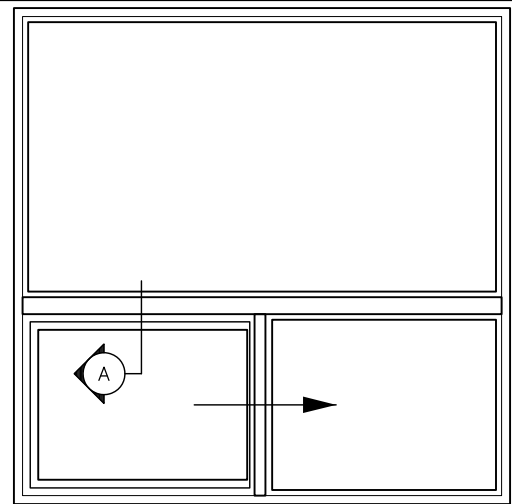

SAMPLE ELEVATION
EXTERIOR VIEW

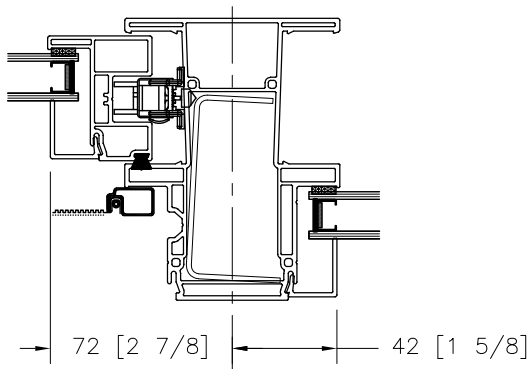

B. SINGLE HUNG - PICTURE
MULLION DETAIL

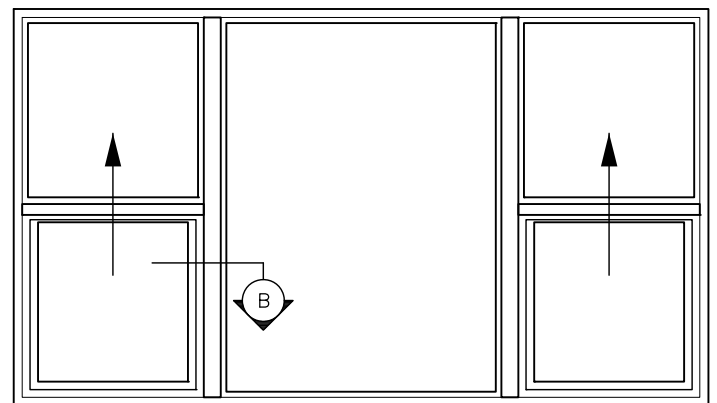

SAMPLE ELEVATION
EXTERIOR VIEW

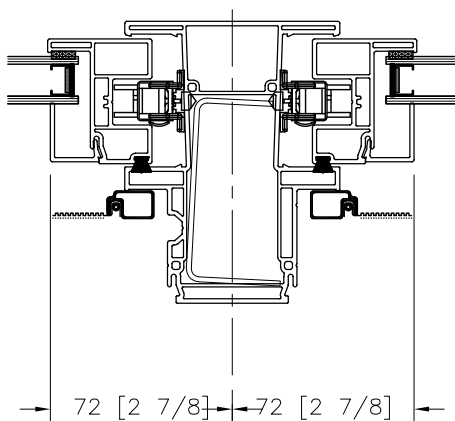

C. SINGLE HUNG - SINGLE HUNG
MULLION DETAIL

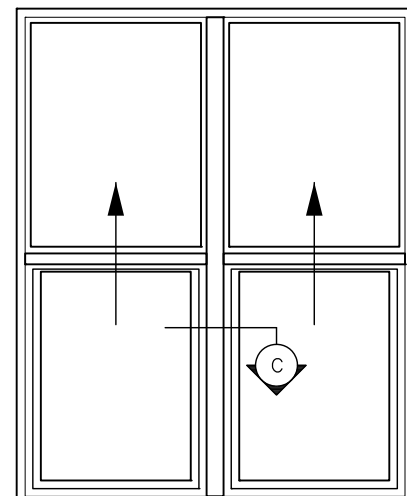

SAMPLE ELEVATION
EXTERIOR VIEW



ALPINE

ULTIMATE PVC GLIDER WINDOWS

6700 SERIES
SECTION DETAILS
OPTION

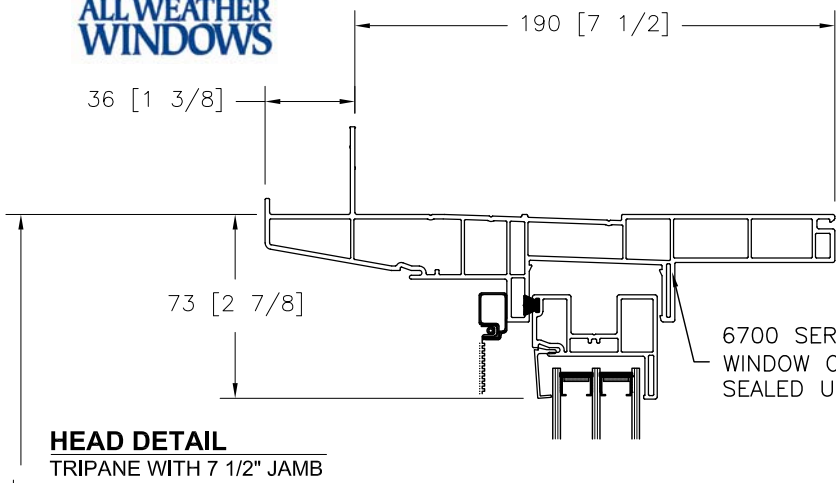

HEAD DETAIL
TRIPANE WITH 7 1/2" JAMB

SECTION A - A

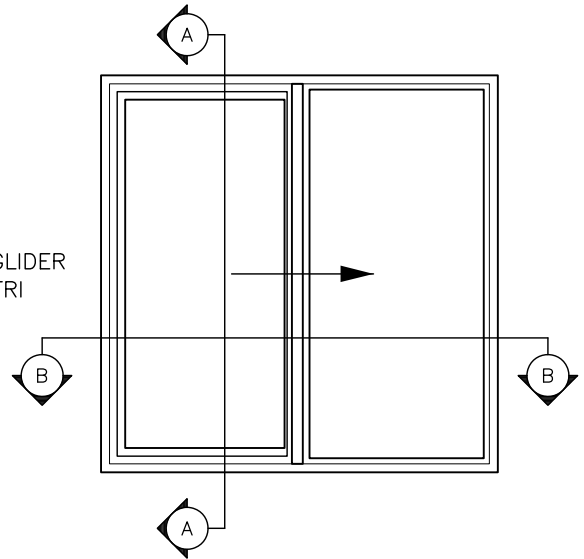

SAMPLE ELEVATION
EXTERIOR VIEW

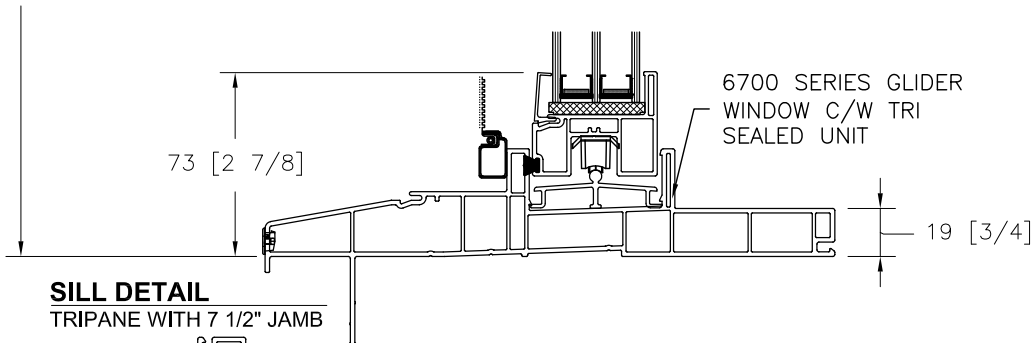

SILL DETAIL
TRIPANE WITH 7 1/2" JAMB

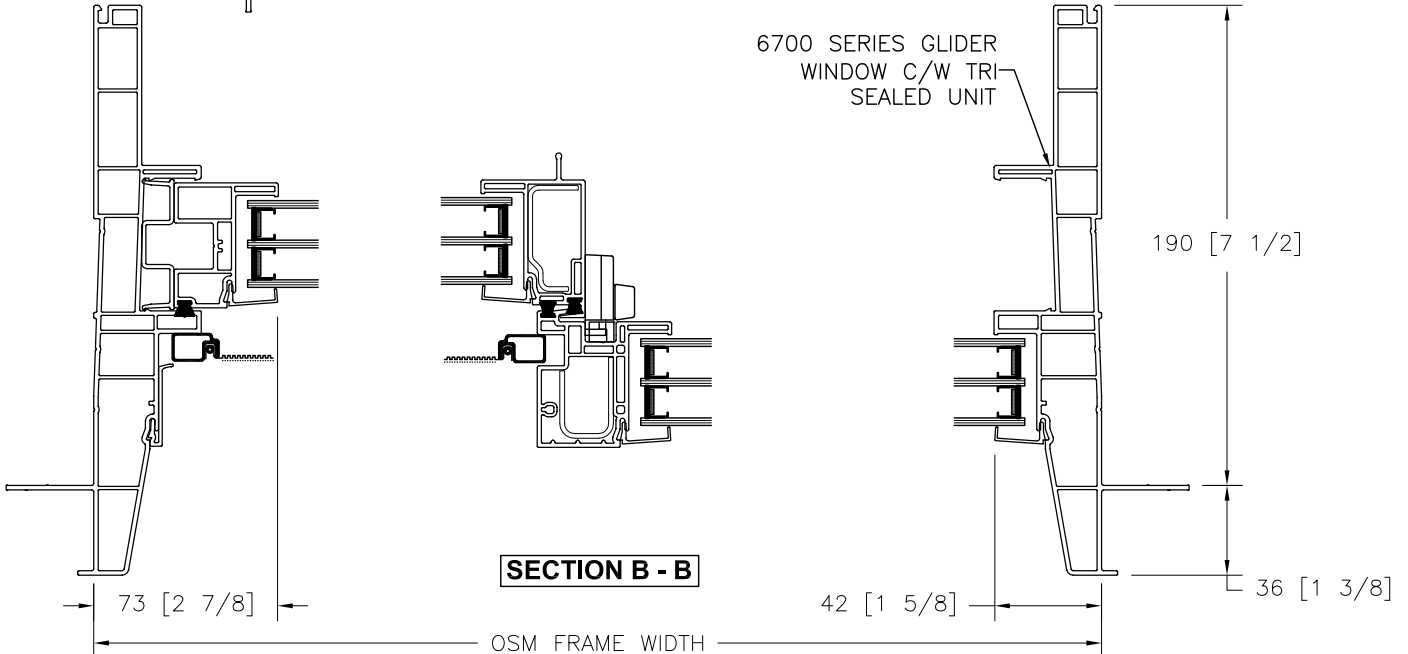

SECTION B - B

JAMB DETAIL
TRIPANE WITH 7 1/2" JAMB



ALPINE

ULTIMATE PVC GLIDER WINDOWS

6700 SERIES

SECTION DETAILS
REINFORCING

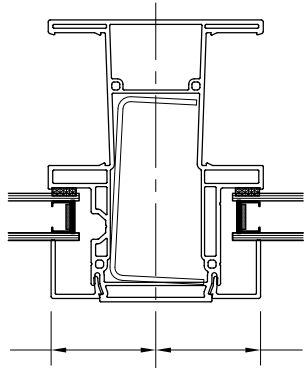

A- PICTURE / PICTURE
STEEL REINFORCED MULLION

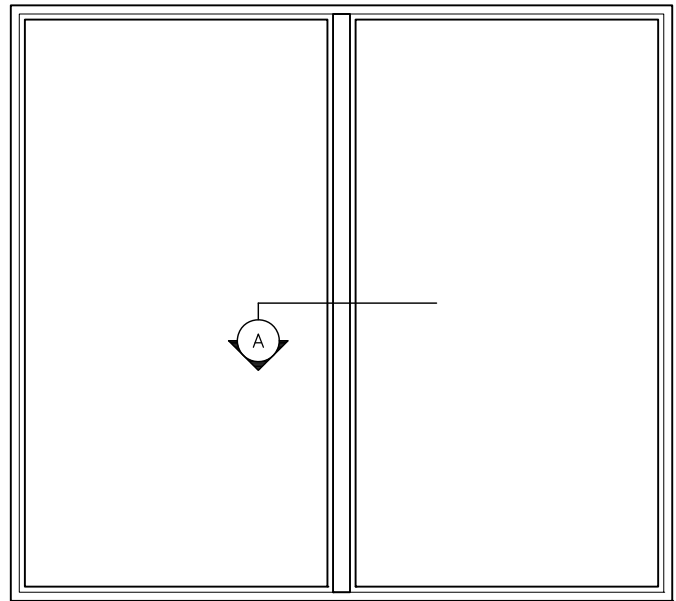

SAMPLE ELEVATION
EXTERIOR VIEW



ALPINE

ULTIMATE PVC GLIDER WINDOWS

6700 SERIES
SECTION DETAILS
WALL DETAILS

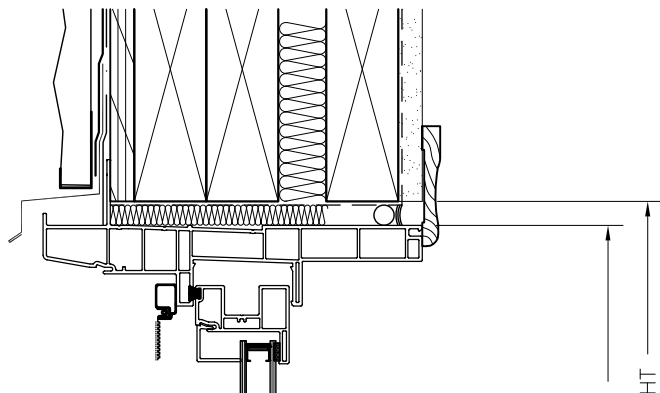

HEAD DETAIL
2x6 STUD WALL

SECTION A - A

OSM FRAME HEIGHT
ROUGH OPENING HEIGHT

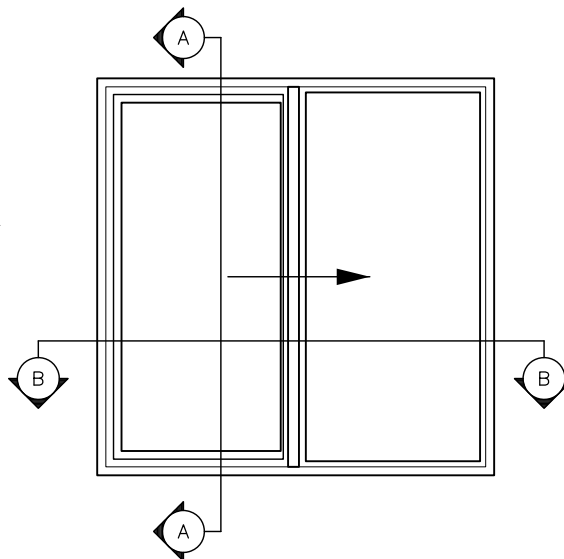

SAMPLE ELEVATION
EXTERIOR VIEW

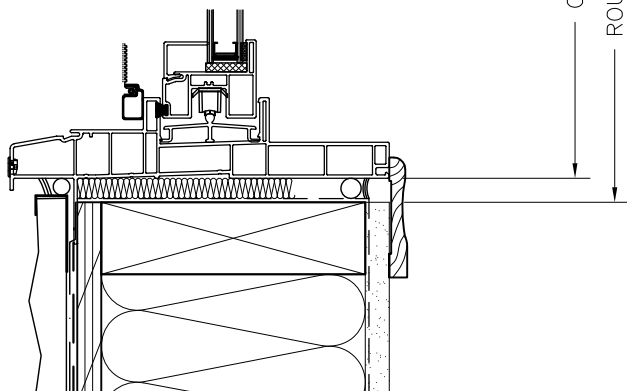

SILL DETAIL
2x6 STUD WALL

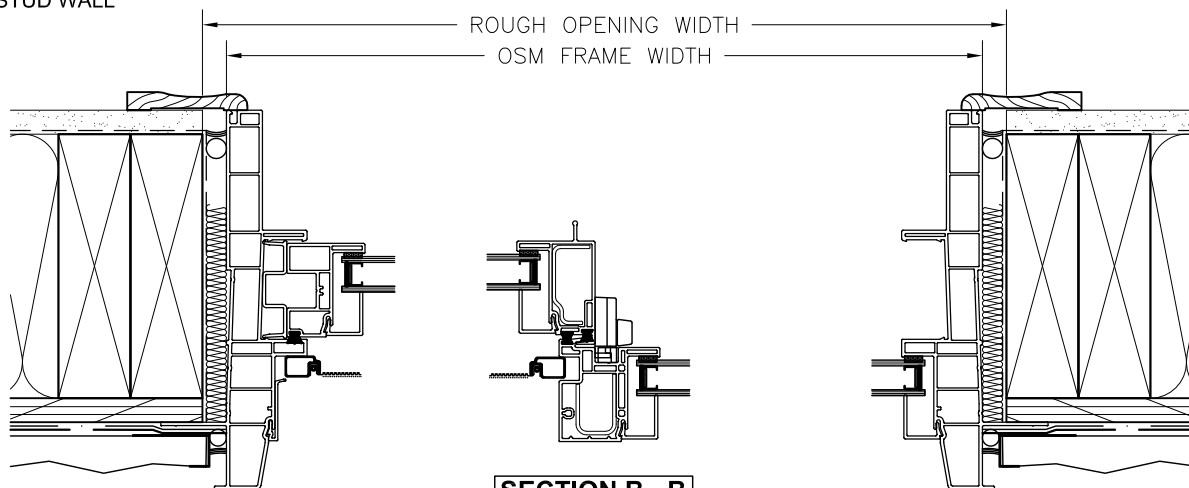

SECTION B - B

JAMB DETAIL
2x6 STUD WALL